

A50-IC(1)

Multi-chambered pet cremation machine for small to large pets

Upper and lower cremation chambers increase throughput with easy operation.

The A50-IC (1) pet cremation machine is streamlined to increase your output efficiently through its two cremation chambers. Pneumatically controlled front loading door with a second lower chamber for easy manual de-ashing to optimize your daily throughput to up to 15 pets.

Designed for safety, performance, and efficiency. The A50-IC (1) Hot Hearth retort continuously recycles heat throughout the cremation chamber, providing 360° heating, reducing cremation time. Unrivaled in its field, boasting a 40% reduction in fuel consumption compared to alternative solutions.



addfield
pet cremation solutions

The addfield difference

- Pre-Fabricated 5/16" & 3/8" robust mild steel casing, seam welded and suitably stiffened/braced where necessary.
- Lightweight, resilient refractory fiber insulation door, providing a tight seal, giving excellent thermal efficiency.
- Primary and secondary chamber lining thickness of 7 inches, rated at 2,642°F.
- Premium paint finish – Steel structures are painted using a two-component, high grade paint system.
- Unique Hot Hearth technology enabling increased efficiency of cremation by providing additional heating below the chamber, encouraging 360° heat distribution.
- Multi-layered refractory lining, using fire bricks and insulation bricks, improving thermal efficiency.

Optional Operation Equipment



Hydraulic Lift Table

Provides an easier way of lifting weights up to 770 lbs., has an extendable bed for safer loading.

Height adjustable up to 51 inches, with a pull lever to smoothly lower the table.



De-ashing Tools

De-ashing tools provide an efficient way to remove ashes from the cremator.

For removing hot ash from the chamber of the cremator straight into the ash box, ready to be processed in the cremulator unit.



Pet Cremulator

The cremulator processes the calcined bones of domestic animals and grinds them into a fine ash for returning to the owner.

The pulverization takes 2 minutes from bone material to a final ash residue.

Distributed by
Cremation Systems
15660 South LaSalle Street
South Holland, IL 60473

Cremation Systems[™]
Division of Armil CFS, Inc.

© 2024, Cremation Systems

A50-IC(1)

Multi-chambered pet cremation machine for small to large pets

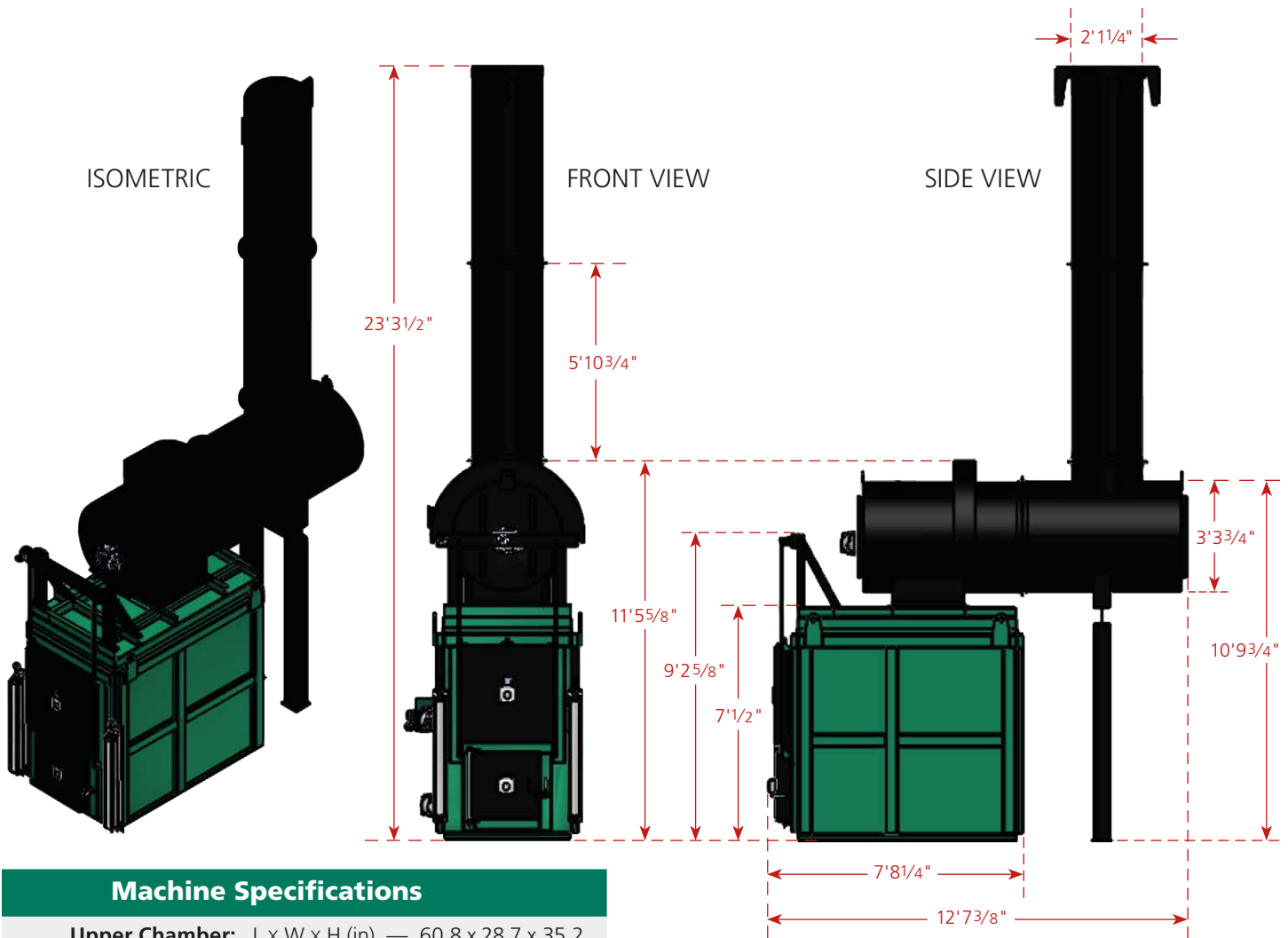

Machine Specifications

Upper Chamber: L x W x H (in) — 60.8 x 28.7 x 35.2

Lower Chamber: L x W x H (in) — 60.8 x 28.7 x 25.7

Weight: (approx) 20,900 lbs

Nominal Burn Rate: 99 lbs/hr

Thermal Capacity: 1,000,000 btu

Power Supply: 50/60 hz (3 Phase) 220–240v

Door Opening: (in) 26 x 24.4

Hot Hearth Principle: Yes

Fuel Types: Natural Gas, Propane

Control Panel: PLC

We reserve the right to change the specification, dimensions and quality of materials from time to time, so long as the alteration is minor or an improvement to the said product.

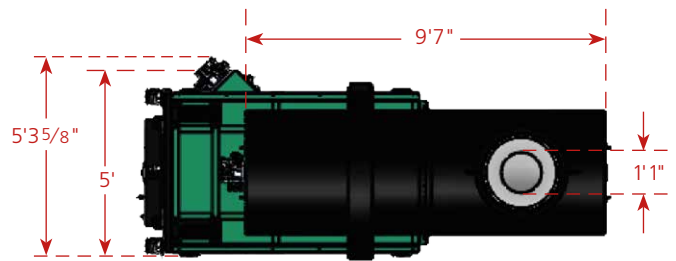

© 2024, Cremation Systems



Distributed by Cremation Systems
15660 South LaSalle Street
South Holland, IL 60473

708-339-6810 • Fax: 708-339-0517
www.cremsys.com

addfield
pet cremation solutions

