

# Processor

Compact cremation machine for processing the ash remains after a cremation.

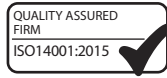
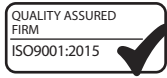

## Pet Processor

The Addfield Pet processor is the ideal accessory to accompany any pet cremation business. Constructed from long lasting, rugged mild steel the processor rapidly reduces all bone fragments left behind after the cremation process. Grinding them down into a fine, presentable ash in as little as 2 minutes. The result is a more visually appealing remains format for the operators to return to the pet owners.

The processor has a dust tight seal on the drum and the lid which prevents leakage and a robust 6mm thick, mild steel blade.

The advanced remains processing system is dust free and shuts off automatically once the process has finished.



## Ergonomically Friendly

Once completed, it is important to leave the ash to settle in the sealed chamber for 5 minutes before emptying into the ash bowl, using the ergonomically friendly pivoting arm.

The finished remains are a fine ash which makes it ideal for all crematoriums that complete individual cremations. A larger Equine cremulator is also available



### Processor Specification

|                                   |        |
|-----------------------------------|--------|
| External Length (inches)          | 36.8   |
| External Width (inches)           | 12.8   |
| External Height (inches)          | 57.8   |
| Chamber Volume (ft <sup>3</sup> ) | .21    |
| Weight (Approx. lbs)              | 132.25 |

\*We reserve the right to change the specification, dimensions and quality of materials from time to time, so long as the alteration is minor or an improvement to the said product.

# Standard Processor

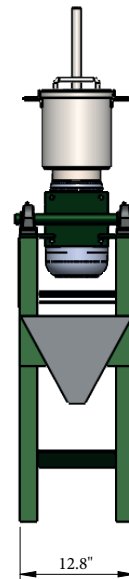
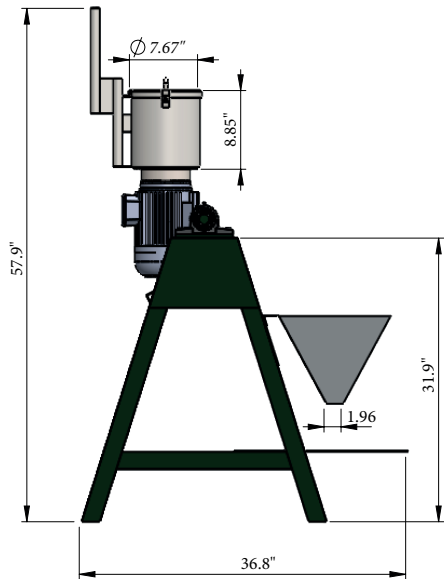
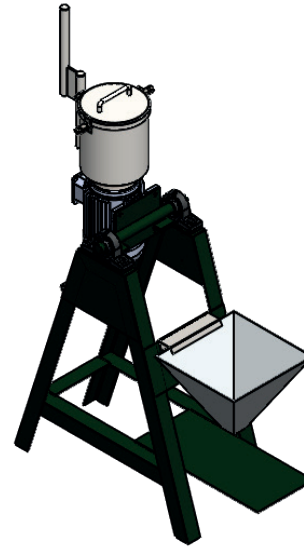
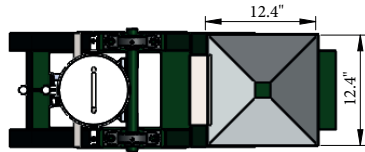

THIRD ANGLE PROJECTION  
(UNLESS STATED OTHERWISE)

MATERIAL:  
N/A  
  
FINISH:  
N/A

TOLERANCES  
(UNLESS STATED OTHERWISE)  
WHOLE NUMBERS ±1.00  
1 DECIMAL PLACE ±0.10  
2 DECIMAL PLACE ±0.05  
ANGLES ±0.50°

WEIGHT:



T: +44 (0)1543 571 280  
F: +44 (0)1543 571 175  
E: sales@addfield.com  
www.addfield.com

Addfield Environmental Systems LTD  
Unit 9, Zone 4  
Burntwood Business Park  
Staffordshire  
WS7 3XD

DRAWN BY: KJ

DATE CREATED: 29/04/2019

PROJECT:

STANDARD CREMULATOR

TITLE:

CREMULATOR GA

| DATE     | DRAWN | CHECKED | APPROVED | DATE     | DRAWN | CHECKED | APPROVED | DATE     | DRAWN | CHECKED | APPROVED | DATE     | DRAWN | CHECKED | APPROVED | DATE       | DRAWN | CHECKED | APPROVED |  |
|----------|-------|---------|----------|----------|-------|---------|----------|----------|-------|---------|----------|----------|-------|---------|----------|------------|-------|---------|----------|--|
|          |       |         |          |          |       |         |          |          |       |         |          |          |       |         |          | 29/04/2019 | KJ    |         |          |  |
| D        |       |         |          | C        |       |         |          | B        |       |         |          | A        |       |         |          |            |       |         |          |  |
| COMMENTS |       |         |          | COMMENTS |       |         |          | COMMENTS |       |         |          | COMMENTS |       |         |          | COMMENTS   |       |         |          |  |

Addfield Environmental Systems LTD (2018)  
This drawing and any information or  
descriptive material set out on it are the confidential and  
copyright property of Addfield Environmental Systems, and  
MUST NOT BE DISCLOSED, COPIED, LOANED in whole or part  
or used for any purpose without the written permission of  
Addfield Environmental Systems.

DRAWING No.  
27-GA-001

REV  
—

SHEET No. 1 OF 1

SCALE: 1:15

A3